



HB200C

Most of the companies are under constant pressure to lower operating cost in order to stay competitive in the market. Good lighting ensures optimal visual conditions, comfort and sense of safety while enabling huge energy savings. Good lighting products produce right amount of light at the right place ensure optimal returns on your lighting energy bill. NexusLED HB lighting system delivers attractive energy-efficient LED high bay lighting.

Benefits

- . Reduced operational costs
- . Lower maintenance costs
- . Easy and fast installation, all in one unit

Features

- . 50% energy savings compared to HID
- . Long life-span of 50,000 hours at Ta 25°C
- . Meet CE/UL standard power driver
- . No mercury or toxic gas
- . RoHS compliant

Application

- . Warehouses
- . Covered car parks
- . Covered walkway



Specification :

Model	HB200C-C65-90
AC Input Voltage	100 ~ 240Vac, 50 ~ 60Hz
System Power	200 W +/- 5%
Luminous Efficacy	>75 lm/W
LED Driving Current	3,000 mA
Luminous Flux (Initial Lumen)	24,150 lm
Light Color	Cool White (6000 ~ 7000K)
Color Rendering index (CRI)	> 70
Beam Angle	90°
Operating Temperature	-20°C ~ +35°C
Storage Temperature	-20°C ~ +75°C
Lifetime (typical)	50,000 Hrs @ Ta 25°C
LED Lumen Maintenance	LM80
Heatsink Material	Extruded Aluminum
Luminaire Cover Material	Clear Polycarbonate
Body Color	Silver
Size (∅) X (H)	486mm x 400mm
Weight	5.5kg
IP rating	IP20
Electrical Safety	Class II
LED Driver Compliant	CE, IEC

Photometric data :

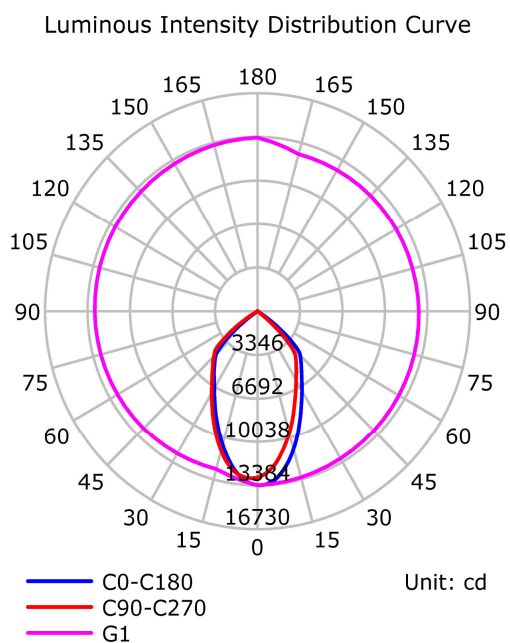

Illuminance at a Distance

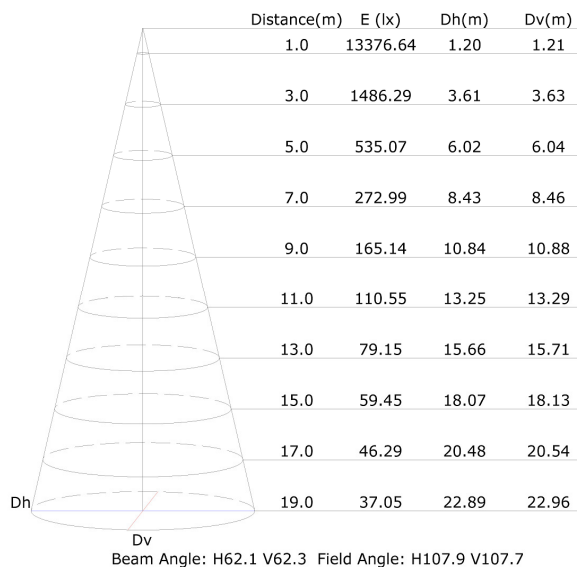

www.nexusled.com

Dimensions :

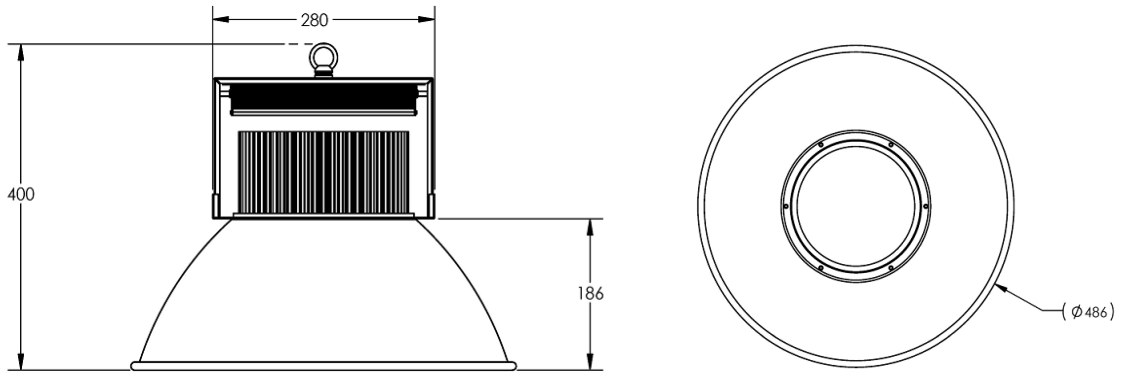

Model Name Structure:

